

## A.21. OXIDIZING PROPERTIES (LIQUIDS)

### 1. METHOD

#### 1.1 INTRODUCTION

This test method is designed to measure the potential for a liquid substance to increase the burning rate or burning intensity of a combustible substance, or to form a mixture with a combustible substance which spontaneously ignites, when the two are thoroughly mixed. It is based on the UN test for oxidizing liquids (1) and is equivalent to it. However, as this method A.21 is primarily designed to satisfy the requirements of Dir 67/548, comparison with only one reference substance is required. Testing and comparison to additional reference substances may be necessary when the results of the test are expected to be used for other purposes.<sup>1</sup>

This test need not be performed when examination of the structural formula establishes beyond reasonable doubt that the substance is incapable of reacting exothermically with a combustible material.

It is useful to have preliminary information on any potential explosive properties of the substance before performing this test.

This test is not applicable to solids, gases, explosive or highly flammable substances, or organic peroxides.

This test may not need be performed when results for the test substance in the UN test for oxidizing liquids (1) are already available.

#### 1.2 DEFINITIONS AND UNITS

**Mean pressure rise time** is the mean of the measured times for a mixture under test to produce a pressure rise from 690 kPa to 2070 kPa above atmospheric.

#### 1.3 REFERENCE SUBSTANCE

65% (w/w) aqueous nitric acid (analytical grade) is required as a reference substance.<sup>2</sup>

Optionally, if the experimenter foresees that the results of this test may eventually be used for other purposes,<sup>1</sup> testing of additional reference substances may also be appropriate.<sup>3</sup>

#### 1.4 PRINCIPLE OF THE TEST METHOD

The liquid to be tested is mixed in a 1 to 1 ratio, by mass, with fibrous cellulose and introduced into a pressure vessel. If during mixing or filling spontaneous ignition occurs, no further testing is necessary.

If spontaneous ignition does not occur the full test is carried out. The mixture is heated in a pressure vessel and the mean time taken for the pressure to rise from 690 kPa to 2070 kPa above atmospheric is determined. This is compared with the mean pressure rise time for the 1:1 mixture of the reference substance(s) and cellulose.

#### 1.5 QUALITY CRITERIA

In a series of five trials on a single substance no results should differ by more than 30 % from the arithmetic mean. Results that differ by more than 30 % from the mean should be discarded, the mixing and filling procedure improved and the testing repeated.

<sup>1</sup> As, for example, in the framework of UN transport regulations.

<sup>2</sup> The acid should be titrated before testing to confirm its concentration.

<sup>3</sup> E.g.: 50% (w/w) perchloric acid and 40% (w/w) sodium chlorate are used in reference 1.

## 1.6 DESCRIPTION OF THE METHOD

### 1.6.1 Preparation

#### 1.6.1.1 Combustible substance

Dried, fibrous cellulose with a fibre length between 50 and 250  $\mu\text{m}$  and a mean diameter of 25  $\mu\text{m}$ ,<sup>4</sup> is used as the combustible material. It is dried to constant weight in a layer not more than 25 mm thick at 105 °C for 4 hours and kept in a desiccator, with desiccant, until cool and required for use. The water content of the dried cellulose should be less than 0.5% by dry mass<sup>5</sup>. If necessary, the drying time should be prolonged to achieve this.<sup>6</sup> The same batch of cellulose is to be used throughout the test.

#### 1.6.1.2 Apparatus

##### 1.6.1.2.1 Pressure vessel

A pressure vessel is required. The vessel consists of a cylindrical steel pressure vessel 89 mm in length and 60 mm in external diameter (see figure 1). Two flats are machined on opposite sides (reducing the cross-section of the vessel to 50 mm) to facilitate holding whilst fitting up the firing plug and vent plug. The vessel, which has a bore of 20 mm diameter is internally rebated at either end to a depth of 19 mm and threaded to accept 1" British Standard Pipe (BSP) or metric equivalent. A pressure take-off, in the form of a side arm, is screwed into the curved face of the pressure vessel 35 mm from one end and at 90° to the machined flats. The socket for this is bored to a depth of 12 mm and threaded to accept the 1/2" BSP (or metric equivalent) thread on the end of the side-arm. If necessary, an inert seal is fitted to ensure a gas-tight seal. The side-arm extends 55 mm beyond the pressure vessel body and has a bore of 6 mm. The end of the side-arm is rebated and threaded to accept a diaphragm type pressure transducer. Any pressure-measuring device may be used provided that it is not affected by the hot gases or the decomposition products and is capable of responding to rates of pressure rise of 690-2070 kPa in not more than 5 ms.

The end of the pressure vessel farthest from the side-arm is closed with a firing plug which is fitted with two electrodes, one insulated from, and the other earthed to, the plug body. The other end of the pressure vessel is closed by a bursting disk (bursting pressure approximately 2200 kPa) held in place with a retaining plug which has a 20 mm bore. If necessary, an inert seal is used with the firing plug to ensure a gas-tight fit. A support stand (figure 2) holds the assembly in the correct attitude during use. This usually comprises a mild steel base plate measuring 235 mm x 184 mm x 6 mm and a 185 mm length of square hollow section (S.H.S.) 70 mm x 70 mm x 4 mm.

A section is cut from each of two opposite sides at one end of the length of S.H.S. so that a structure having two flat sided legs surmounted by 86 mm length of intact box section results. The ends of these flat sides are cut to an angle of 60° to the horizontal and welded to the base plate. A slot measuring 22 mm wide x 46 mm deep is machined in one side of the upper end of the base section such that when the pressure vessel assembly is lowered, firing plug end first, into the box section support, the side-arm is accommodated in the slot. A piece of steel 30 mm wide and 6 mm thick is welded to the lower internal face of the box section to act as a spacer. Two 7 mm thumb screws, tapped into the opposite face, serve to hold the pressure vessel firmly in place. Two 12 mm wide strips of 6 mm thick steel, welded to the side pieces abutting the base of the box section, support the pressure vessel from beneath.

<sup>4</sup> e.g. Whatman Column Chromatographic Cellulose Powder CF 11, catalogue no 4021 050

<sup>5</sup> Confirmed by (e.g.) Karl-Fisher titration

<sup>6</sup> Alternatively, this water content can also be achieved by (e.g.) heating at 105 °C under vacuum for 24 h

#### 1.6.1.2.2 Ignition System

The ignition system consists of a 25 cm long Ni/Cr wire with a diameter 0.6 mm and a resistance of 3.85 ohm/m. The wire is wound, using a 5 mm diameter rod, in the shape of a coil and is attached to the firing plug electrodes. The coil should have one of the configurations shown in figure 3. The distance between the bottom of the vessel and the underside of the ignition coil should be 20 mm. If the electrodes are not adjustable, the ends of the ignition wire between the coil and the bottom of the vessel should be insulated by a ceramic sheath. The wire is heated by a constant current power supply able to deliver at least 10 A.

#### 1.6.2 Performance of the test<sup>7</sup>

The apparatus, assembled complete with pressure transducer and heating system but without the bursting disk in position, is supported firing plug end down. 2.5 g of the liquid to be tested is mixed with 2.5 g of dried cellulose in a glass beaker using a glass stirring rod<sup>8</sup>. For safety, the mixing should be performed with a safety shield between the operator and mixture. If the mixture ignites during mixing or filling, no further testing is necessary. The mixture is added, in small portions with tapping, to the pressure vessel making sure that the mixture is packed around the ignition coil and is in good contact with it. It is important that the coil is not distorted during the packing process as this may lead to erroneous results<sup>9</sup>. The bursting disk is placed in position and the retaining plug is screwed in tightly. The charged vessel is transferred to the firing support stand, bursting disk uppermost, which should be located in a suitable, armoured fume cupboard or firing cell. The power supply is connected to the external terminals of the firing plug and 10 A applied. The time between the start of mixing and switching on the power should not exceed 10 minutes.

The signal produced by the pressure transducer is recorded on a suitable system which allows both evaluation and the generation of a permanent record of the time pressure profile obtained (e.g. a transient recorder coupled to a chart recorder). The mixture is heated until the bursting disk ruptures or until at least 60 s have elapsed. If the bursting disk does not rupture, the mixture should be allowed to cool before carefully dismantling the apparatus, taking precautions to allow for any pressurization which may occur. Five trials are performed with the test substance and the reference substance(s). The time taken for the pressure to rise from 690 kPa to 2070 kPa above atmospheric is noted. The mean pressure rise time is calculated.

In some cases, substances may generate a pressure rise (too high or too low), caused by chemical reactions not characterizing the oxidizing properties of the substance. In these cases, it may be necessary to repeat the test with an inert substance, e.g. diatomite (kieselguhr), in place of the cellulose in order to clarify the nature of the reaction.

Please notice that only European Community's legislation published in the paper editions of the Official Journal of the European Communities is deemed authentic. This text was prepared from the draft protocol sent for approval to the Member States. Minor editorial differences may exist between this version and the one agreed and published in the paper edition of the Official Journal. Care has been taken to ensure correctness of the text; nevertheless possibility of errors cannot be completely excluded. In case of doubt the reader is advised to consult the Official Journal. This method can be found in Dir 2004/73/EC (O. J. L152 2004). A complete list of Annex V Testing Methods and the corresponding OJ can be downloaded from a previous page in this site.

<sup>7</sup> Mixtures of oxidizers with cellulose must be treated as potentially explosive and handled with due care

<sup>8</sup> In practice this can be achieved by preparing a 1:1 mixture of the liquid to be tested and cellulose in a greater amount than needed for the trial and transferring  $5 \pm 0.1$  g to the pressure vessel. The mixture is to be freshly prepared for each trial.

<sup>9</sup> In particular, contact between the adjacent turns of the coil must be avoided.

**DATA**

Pressure rise times for both the test substance and the reference substance(s). Pressure rise times for the tests with an inert substance, if performed.

## 2.1 TREATMENT OF RESULTS

The mean pressure rise times for both the test substance and the reference substances(s) are calculated. The mean pressure rise time for the tests with an inert substance (if performed) is calculated.

Some examples of results are shown in Table 1

**Table 1**  
Examples of results <sup>d)</sup>

Substance <sup>c)</sup>	Mean pressure rise time for a 1:1 mixture with cellulose (ms)
Ammonium dichromate, saturated aqueous solution	20800
Calcium nitrate, saturated aqueous solution	6700
Ferric nitrate, saturated aqueous solution	4133
Lithium perchlorate, saturated aqueous solution	1686
Magnesium perchlorate, saturated aqueous solution	777
Nickel nitrate, saturated aqueous solution	6250
Nitric acid, 65 %	4767 <sup>a)</sup>
Perchloric acid, 50 %	121 <sup>a)</sup>
Perchloric acid, 55 %	59
Potassium nitrate, 30 % aqueous solution	26690
Silver nitrate, saturated aqueous solution	- <sup>b)</sup>
Sodium chlorate, 40 % aqueous solution	2555 <sup>a)</sup>
Sodium nitrate, 45 % aqueous solution	4133
<i>Inert Substance</i>	
Water:cellulose	- <sup>b)</sup>

- a) Mean value from interlaboratory comparative trials  
 b) Maximum pressure of 2070 kPa not reached  
 c) Saturated solutions should be prepared at 20 °C  
 d) See reference (1) for classification under the UN transport scheme,

### 3 REPORT

#### 3.1 TEST REPORT

The test report should include the following information:

- the identity, composition, purity, etc of the substance tested;
- the concentration of the test substance;
- the drying procedure of the cellulose used
- the water content of the cellulose used
- the results of the measurements;
- the results from tests with an inert substance, if any;
- the calculated mean pressure rise times;
- any deviations from this method and the reasons for them;
- all additional information or remarks relevant to the interpretation of the results;

#### 3.2 INTERPRETATION OF THE RESULTS<sup>10</sup>

The test results are assessed on the basis of:

- a) whether the mixture of test substance and cellulose spontaneously ignites; and
- b) the comparison of the mean time taken for the pressure to rise from 690 kPa to 2070 kPa with that of the reference substance(s).

A liquid substance is to be considered as an oxidizer when:

- a) a 1:1 mixture, by mass, of the substance and cellulose spontaneously ignites; or
- b) a 1:1 mixture, by mass, of the substance and cellulose exhibits a mean pressure rise time less than or equal to the mean pressure rise time of a 1:1 mixture, by mass, of 65% (w/w) aqueous nitric acid and cellulose.

In order to avoid a false positive result, if necessary, the results obtained when testing the substance with an inert material should also be considered when interpreting the results.

### 4 REFERENCES

- (1) Recommendations on the Transport of Dangerous Goods, Manual of Tests and Criteria. 3rd revised edition. UN Publication No: ST/SG/AC.10/11/Rev. 3, 1999, page 342. Test O.2: Test for oxidizing liquids.

---

<sup>10</sup> See reference 1 for interpretation of the results under the UN transport regulations using several reference substances.

Figure 1

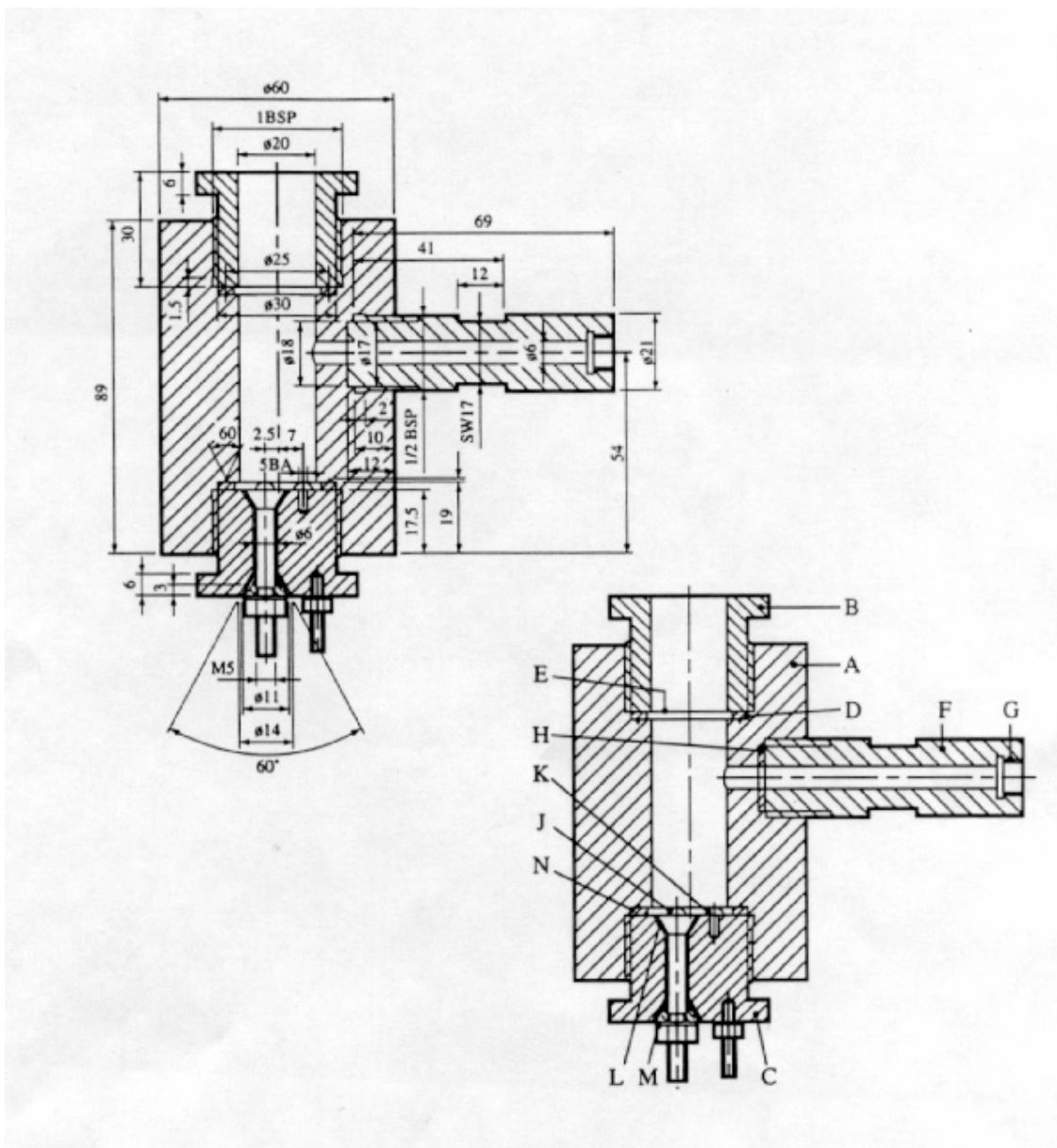

Pressure vessel

- |                              |                                  |                         |
|------------------------------|----------------------------------|-------------------------|
| (A) Pressure vessel body     | (B) Bursting disk retaining plug | (C) Firing plug         |
| (D) Soft lead washer         | (E) Bursting disc                | (F) Side arm            |
| (G) Pressure transducer head | (H) Washer                       | (J) Insulated electrode |
| (K) Earthed electrode        | (L) Insulation                   | (M) Steel cone          |
| (N) Washer distorting groove |                                  |                         |

Please notice that only European Community's legislation published in the paper editions of the Official Journal of the European Communities is deemed authentic. This text was prepared from the draft protocol sent for approval to the Member States. Minor editorial differences may exist between this version and the one agreed and published in the paper edition of the Official Journal. Care has been taken to ensure correctness of the text; nevertheless possibility of errors cannot be completely excluded. In case of doubt the reader is advised to consult the Official Journal. This method can be found in Dir 2004/73/EC (O.J. L152 2004). A complete list of Annex V Testing Methods and the corresponding OJ can be downloaded from a previous page in this site.

Figure 2  
Support stand

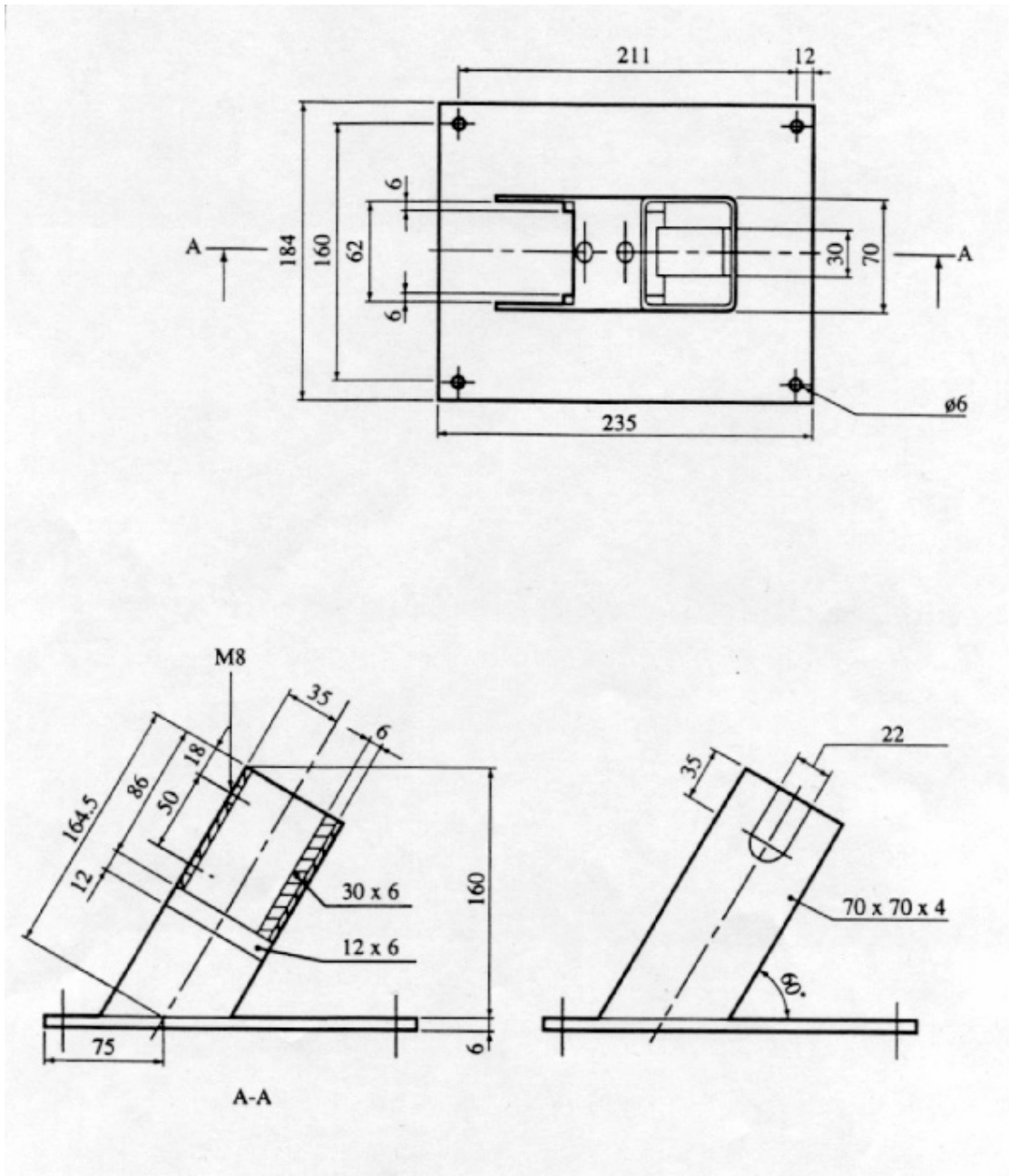

Please notice that only European Community's legislation published in the paper editions of the Official Journal of the European Communities is deemed authentic. This text was prepared from the draft protocol sent for approval to the Member States. Minor editorial differences may exist between this version and the one agreed and published in the paper edition of the Official Journal. Care has been taken to ensure correctness of the text; nevertheless possibility of errors cannot be completely excluded. In case of doubt the reader is advised to consult the Official Journal. This method can be found in Dir 2004/73/EC (O.J. L152 2004). A complete list of Annex V Testing Methods and the corresponding OJ can be downloaded from a previous page in this site.

Figure 3  
Ignition System

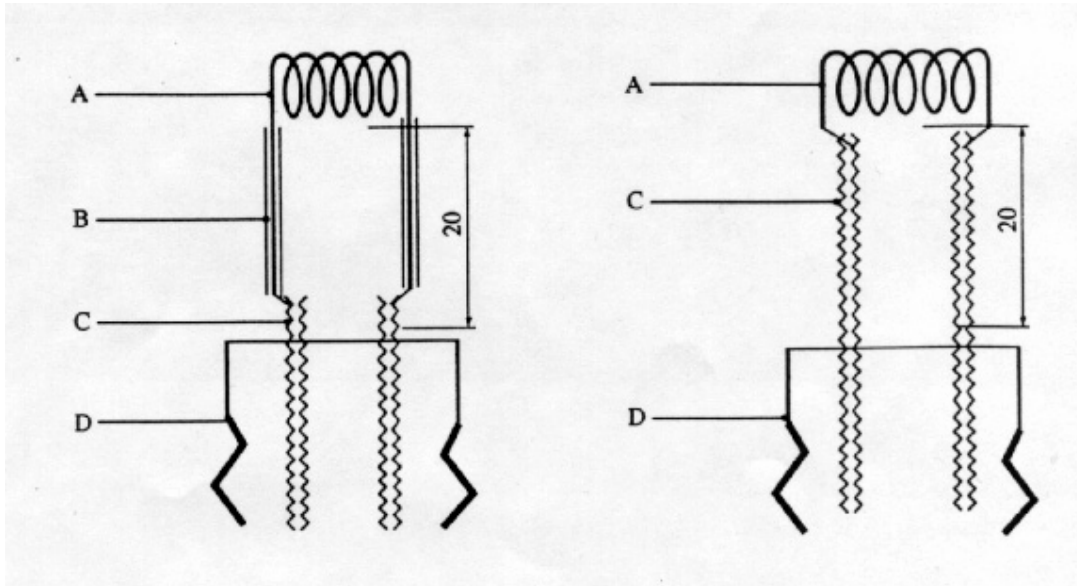

(A) Ignition coil

(B) Insulation

(C) Electrodes

(D) Firing plug

Note: either of these configurations may be used.

Please notice that only European Community's legislation published in the paper editions of the Official Journal of the European Communities is deemed authentic. This text was prepared from the draft protocol sent for approval to the Member States. Minor editorial differences may exist between this version and the one agreed and published in the paper edition of the Official Journal. Care has been taken to ensure correctness of the text; nevertheless possibility of errors cannot be completely excluded. In case of doubt the reader is advised to consult the Official Journal. This method can be found in Dir 2004/73/EC (O.J. L152 2004). A complete list of Annex V Testing Methods and the corresponding OJ can be downloaded from a previous page in this site.